



ALTER

AIR CONDITIONING



Alter Airconditioning Co.,Ltd.

99/5 Moo.20 Lamlukka, Lamlukka, Pathumthani 12150 Thailand.

Tel: +662 023 4172-74 Fax: +662 023 4175

E-mail : sales@alter.co.th Website : <http://www.alter.co.th>



COMPANY PROFILE

GENERAL INFORMATION

The Alter Air Handling Units

are modular in design and is available in both horizontal and vertical configuration with a variety of discharge arrangement. These units may be arranged to meet almost any space or duct requirements. Each unit comes complete, cooling coil, motor and drive package and it is also available with a choice of accessories such as filter section, mixing box section, face and bypass damper, etc. to meet any air-condition, or filtration needs.

ALTER AIRCONDITIONING COMPANY LTD.,

was established in 1989 as a sub-contracting company mainly involving in the Construction Heating, Ventilation and Air Conditioning systems / clean rooms / environmental buildings and factories utilities systems. later in 1991 a joint-venture company with a Japanese air handling units in Thailand to serve the local Japanese market only. at the end of 2003, the Thai partners decided to spit out to serve the local market more comprehensively with newer technology from European manufacturers.

ISO 9001 :2008



ALTER SALES SERVICE

To support all our customers should any problems arise during installations, operations and maintenance period at all times.

EUROVENT



ISO 14001 : 2004



PRODUCT RANGE

Model ALT50	Module		Max Air Volume (CMH)	Coil Face Area (m ²)	Coil Face Velocity (m/s)
	Height (Module)	Width (Module)			
030-02-02	2.0	2.0	3,000	0.37	2.24
045-02-03	2.0	3.0	4,500	0.56	2.24
045-03-02	3.0	2.0	4,500	0.56	2.24
060-02-04	2.0	4.0	6,000	0.74	2.24
060-03-03	3.0	3.0	6,000	0.84	1.99
090-03-04	3.0	4.0	9,000	1.11	2.24
120-04-04	4.0	4.0	12,000	1.49	2.24
150-04-05	4.0	5.0	15,000	1.86	2.24
150-05-04	5.0	4.0	15,000	1.86	2.24
180-04-06	4.0	6.0	18,000	2.23	2.24
180-05-05	5.0	5.0	18,000	2.32	2.15
225-05-06	5.0	6.0	22,500	2.79	2.24
240-04-08	4.0	8.0	24,000	2.97	2.24
270-06-06	6.0	6.0	27,000	3.34	2.24
315-06-07	6.0	7.0	31,500	3.90	2.24
315-07-06	7.0	6.0	31,500	3.90	2.24
360-06-08	6.0	8.0	36,000	4.46	2.24
360-07-07	7.0	7.0	36,000	4.55	2.20
420-07-08	7.0	6.0	42,000	5.20	2.24
450-06-10	6.0	10.0	45,000	5.57	2.24
480-08-08	8.0	8.0	48,000	5.94	2.24
525-07-10	7.0	10.0	52,500	6.50	2.24
600-08-10	8.0	10.0	60,000	7.43	2.24
630-07-12	7.0	12.0	63,000	7.80	2.24
660-08-11	8.0	11.0	66,000	8.17	2.24
720-08-12	8.0	12.0	72,000	8.92	2.24

Dimension Calculation

External AHU Height : Module x 305 + 240 + 100 + Base AHU

External AHU Width : Module x 305 + 325 + 100

Example : Model ALT50-045-02-03

External AHU Height : 2 x 305 + 240 + 100 + 100 = 1050 mm.

External AHU Width : 3 x 305 + 325 + 100 = 1340 mm.

COMPUTER PROGRAM.

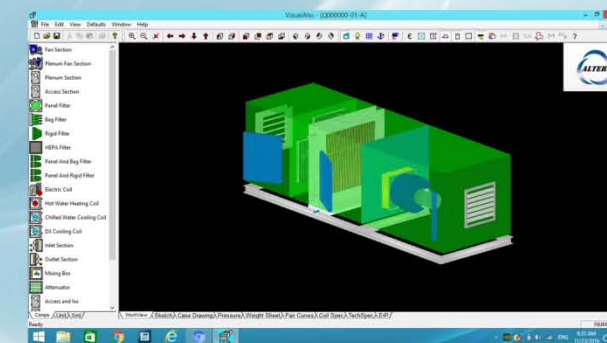

TREATMENT SECTION



Heat Pipe

Heat pipes may be described as having two sections: pre cool and reheat. The first section is located in the incoming air stream. When warm air passes over the heat pipes, the refrigerant vaporizes, carrying heat to the second section of heat pipes, placed downstream. Because some heat has been removed from the air before encountering the evaporator coil, the incoming air stream section is called the pre cool heat pipe.

Hot Gas Re Heat

When compressor is running to reduce room temperature (sensible heat) and humidity (latent heat) respectively, the compressor normally runs beyond the room temperature set point to continue the dehumidifying process. When the night humidity level has been achieved, the system requires reheating to compensate for overcooling. Usually, electric heaters are used.

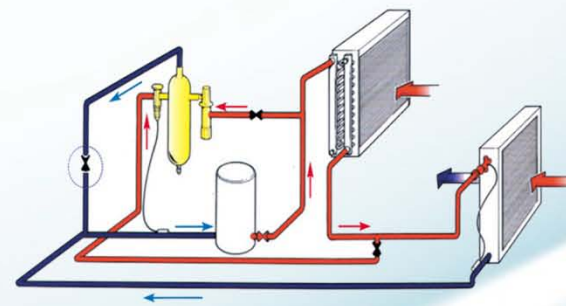

For addition, please refer to technical data Sheet "Door System of Air Handling Units"

Panel 50 mm.

Standard 50 mm. thick infill panel are of double skin construction from pressure injected polyurethane foam insulation

-Thermal conductivity (k) = 0.0204 W/m.K (0.0118 Btu/ft.h.°F)

-Heat transfer coefficient of panel 50 mm thickness (k/L) = 0.408 W/m².K (0.0719 Btu/ ft².h.°F)

-Density = 40 kg/m³

Sandwiched between galvanized steel with pre painted finish and stainless is also available.

DOUBLE SKIN PANEL 50 MM.

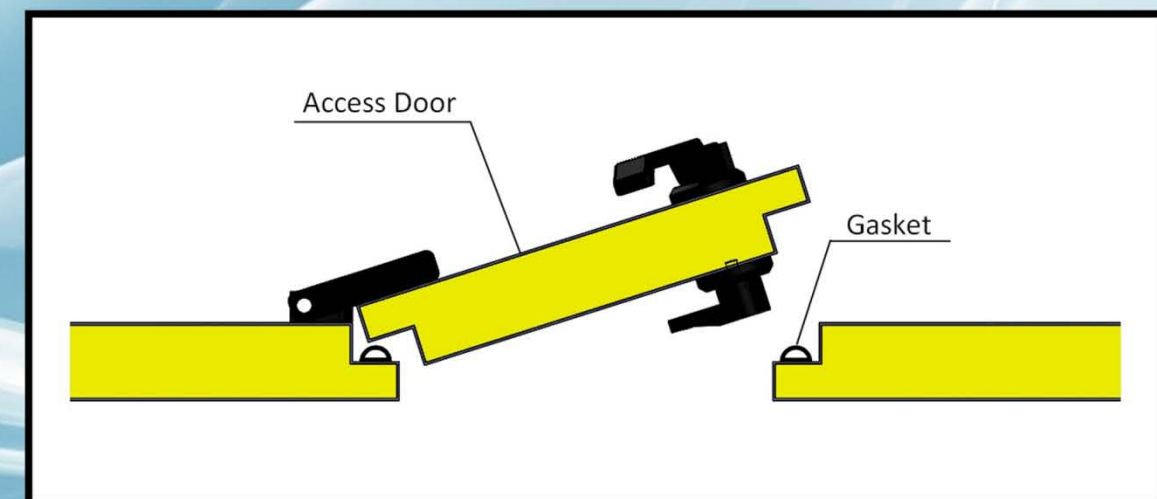
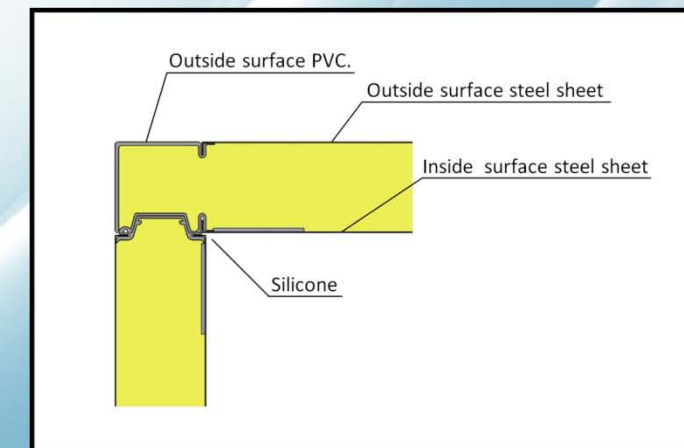



VOLUME DAMPER



WATER PROOF SW.



LAMP



PRESSURE PORT



INSPECTION WINDOW

Filter Section



Fully sealed filter sections are designed for easy withdrawal and renewal of filter cell and, are constructed to house any type of primary or secondary filters of different media with various efficiencies. In Areas of particular importance, such as hospitals and clean rooms, absolute filters can be provided to ensure safe human and machine

Coil Section

Coil are software selected to obtain optimum psychometric efficiency with low air and water pressure drops. Chilled water, Direct Expansion, Hot Water and Steam Coil are constructed from copper tubes, mechanically bonded to aluminum fins as standard. Other fin materials are available including coated aluminum tinned copper. for corrosive flow media, stainless steel tubes and fins are available as an option. The coil assemble completed with carbon steel or copper headers is located within the coil section can be withdrawn from either side.



Fan Section

Fan and motor from the heart of all systems. Forward Curved or Backward Plug Fan Curved non overloading Aero foil Centrifugal fans are available with various outlet configuration. All fan wheels and pulley are individually tested and Precision balanced, statically and dynamically, and Keyed to the shaft. Motor, mounted on slide rails with Provision for easy belt tensioning, drive the fan with heavy duty V-belts. Combination spring and rubber vibration isolators are selected to match the power /weight fan for VAV applications.



Motor

All motors used are 3-phase induction motor Enclosed fan cooled type and the ball bearing are totally sealed which requires no lubrication. Motors are mounted to the blower frame on an adjustable base for easy alignment and belt tensioning.

ACCESSORIES

